

SOFTJET[™] TOUCH

Fold-Softening



Fold-softening of often excessively dry LWC offset papers is a necessity given by the production technique. Also for newsprint and B-quality papers moistening in the fold can be of advantage.

Your advantages

- Immediately improved quality of the printed product
- Improved further processing operation, particularly during the stitching process
- Rectangular and precise folding
- No paper breaking in the fold, not even in the third fold
- Excellent flatness of the folded products, no „round spines“
- Best stacking behaviour on pallets and in the feeder
- Increased performance of the folder
- Better running of subsequent aggregates
- Reduced noise level during the folding process

Features

- User-friendly operation via touch screen
- Individual selection of applicator heads on menu
- Connecting possibility from 1 to 8 applicator heads max.
- Snap-fastener for quick replacement of the applicator head without tools
- Wear and corrosion-resistant ceramic nozzles
- Motorized axial adjustment of the applicator heads with path-measuring system and feedback to the control for accurate repeat positioning
- Medium supply with pneumatic-driven pump
- Mixing ratio fold-softening concentrate/water 1 : 10
- Separate quantity dosage for each applicator head
- Easy maintenance
- Link to press control desk optional



PLANATOL[®]
smart gluing

System

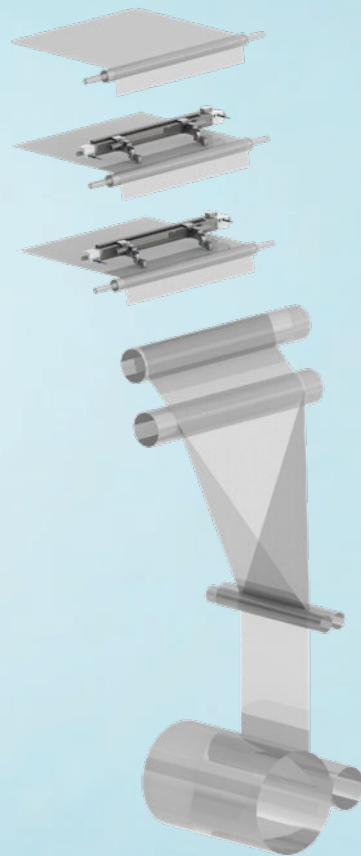

Configuration example

Schematic lay-out of fold-softening in a web press with one folder and 4 applicator heads

Technical data Softjet Touch

Fold-softening application	non-contact application, continuous
Quantity of applicator heads	8 max.
Nozzle diameter	0,2mm standard, further nozzles available
Average consumption per applicator head	0.4l concentrate/h
Axial adjustment	motor-driven with feedback about current positioning
Vertical adjustment	manual
Operation	touch screen 15", integrated operator's manual
Quantity dosage per applicator head	infinitely manually adjustable
Container for fold-softening concentrate	1 x plastic canister 30 kg
Protection class control cabinet	IP65
Voltage	100, 110, 115, 200, 230, 240VAC +/- 15 %
Frequency	50 / 60Hz
Water supply	G ¼"; min. 2 bar, max. 6 bar
Compressed air supply	G ¼"; min. 6 bar, max. 10 bar, free of oil and condensate

Subject to technical modifications.

System and fold-softening concentrate from one source

As manufacturer of machines and adhesives we create the prerequisites for trouble-free running systems with exactly coordinated developments and high production quality. The formulas of our fold-softening concentrates are perfectly adjusted to being processed with our systems.

Learn more about fold-softening concentrates from our brochure „Planatol Fold-Glues“.



Fold-softening concentrate

PLANATOL®
smart gluing

Planatol System GmbH
Fabrikstraße 30-32
83101 Rohrdorf
Germany
www.planatol-system.de

System