

COMBIJET[®] 10PV

Fold-Gluing



The basic system for longitudinal gluing
and fold-softening

Precise, user-friendly, reliable, efficient

PLANATOL[®]
smart gluing

System

Combijet 10PV – The basic system with modular media supply for longitudinal gluing and fold-softening

System cabinet Combijet 10PV with 15" touch screen

Compact structure with integrated control

Operation directly from the Combijet system cabinet, or, optionally from additional operating panels or from press control desks

Clear menu guidance for programming of system parameters, setting of glue line patterns and positioning of the applicator heads



Media supply

Modular supply unit for 1 – 3 plastic canisters each with a capacity of 30kg for adhesive and fold-softening concentrate

Easy and clean changing of canisters

Optimized adhesive application due to higher working pressure

Media supply through double diaphragm pump for adhesive and through piston pump for automatic mixing of fold-softening concentrate with water



Applicator head

Compact structure

Exact intermittent application due to fast-switching applicator heads

Ceramic nozzles extremely wear and corrosion-resistant for contact application, replacement without tools

Different nozzles (double glue line, squeegee) optional



Cross-bars

Cross-bars, protected against soiling of the positioning mechanism

Applicator heads can be positioned horizontally and vertically by hand or by motor

Button for flushing of applicator heads and for functional test directly at the cross-bar

Separate dosage per applicator head for adhesive and fold-softening agent



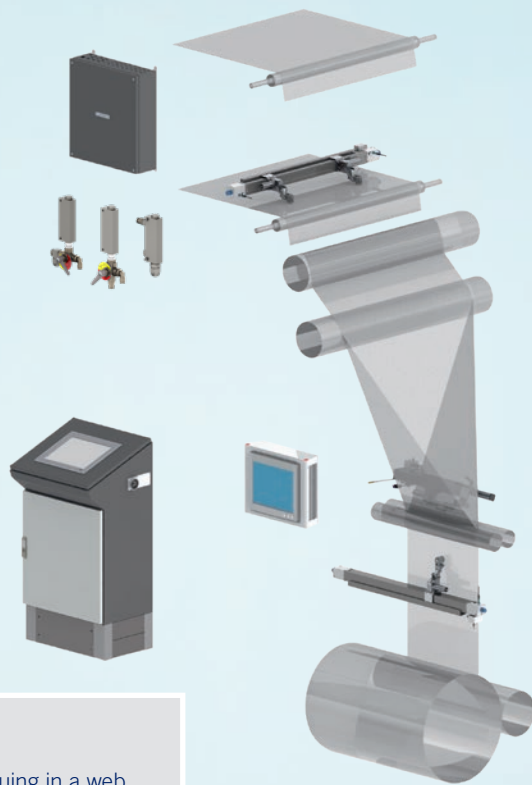

Configuration example

Schematic layout of longitudinal gluing in a web press with one folder and 4 applicator heads and of modular media supply.



Combijet 10PV meets the requirements of small and medium-sized web presses. With intermittent longitudinal gluing and continuous fold-softening the system can realise printed products from 8 to 64 pages with up to 8 applicator heads.

Features

- Application of adhesive and fold-softening agent in contact to the paper web
- Exact intermittent fold-gluing and continuous fold-softening at all web speeds
- 8 applicator heads maximum
- Quick replacement of applicator heads and wear-resistant ceramic nozzles without tools
- Separate quantity dosage for each applicator head
- Per applicator head up to 8 glue lines per cylinder circumference, length and distance freely programmable
- Media supply through pumps from 30kg plastic canisters including filling level control
- Changing of canisters during production
- Flushing and cleaning system
- Motor-driven positioning optional
- Paper web detection and/or web edge scanning optional
- Link to press control desk optional
- Remote diagnosis system optional

Technical Data Combijet 10PV

Adhesive application	contact application, intermittent, up to eight glue lines per cylinder circumference
Fold-Softening application	continuous contact or non-contact application
Quantity of applicator heads	max. 8
Nozzle diameter	gluing and fold-softening with contact application and nozzle diameter 0.5mm, further nozzle diameters available
Maximum web speed	20m/s
Shortest glue line	15mm
Shortest possible interruption	15mm
Axial adjustment	manual, motor-driven optional
Vertical adjustment	manual, motor-driven optional
Operation	touch screen 15", integrated operator's manual
Quantity of programmable glue line patterns	150
Languages	all common languages including Chinese; up to eight languages can directly be selected
Quantity dosage	infinitely adjustable dosage valve per applicator head
Communication between operating panels and peripheral component groups	Ethernet
Communication with the press control desk	Ethernet optional
Speed signal	via central encoder or master axis encoder
Maintenance functions	extensive maintenance functions, remote diagnosis, flushing and cleaning
Adhesive container	1–2 (manual tank switch-over) x plastic canister (white) 30kg
Container for fold-softening concentrate	1 x plastic canister (yellow) 30kg
Protection class control cabinet, peripheral component groups	IP65
Voltage supply	100–240VAC, 380–480VAC ±15%
Frequency	50/60Hz
Water supply	min. 2 bar (without fold-softening min. 3 bar)
Compressed-air supply	G 1/8", G 1/2", 6 bar

Subject to technical modifications

System and adhesive from one single source

As manufacturer of machines and adhesives we create the prerequisites for trouble free running systems with exactly coordinated developments and high production quality. The formulas of our adhesives (viscosity, solid content, special sieving) are adjusted to processing from smallest nozzles at highest speeds.

Learn more about adhesives and fold-softening concentrates from our brochure „Planatol Fold-Glues“



Fold-glues and fold-softening concentrates

Planatol System GmbH
 Fabrikstraße 30-32
 83101 Rohrdorf
 Germany
www.planatol-system.de

PLANATOL®
 smart gluing

System